

# MaEr Fan Motor

Professional · Honest · Human Oriented

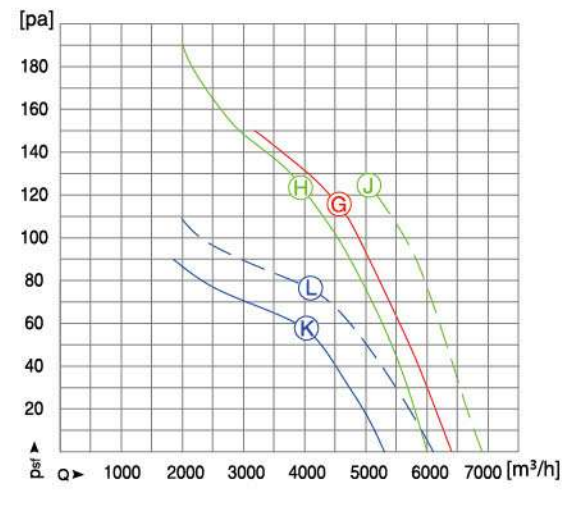

Ø 500 AC AXIAL FAN 外转子轴流风机

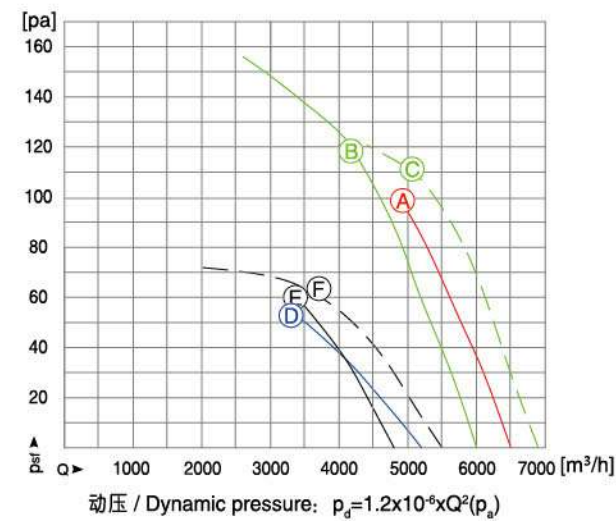

| 型号<br>Model        | 电压<br>Voltage | 频率<br>Frequency | 电容器<br>Capacitor | 曲线<br>Curve | 输入功率<br>Power | 转速<br>RPM | 电流<br>Current | 静压<br>Psf | 环境温度<br>Temp. | 静压效率<br>ηsf | 能效值<br>EFF.Grade | 噪声<br>Noise | 备注<br>Note |
|--------------------|---------------|-----------------|------------------|-------------|---------------|-----------|---------------|-----------|---------------|-------------|------------------|-------------|------------|
|                    | V             | Hz              | μF/450V          | NO.         | W             | r/min     | A             | Pa        | ℃             | %           | N                | dB(A)       |            |
| YDWF102L35P4-□-500 | 1~220         | 50              | 10               | A           | 424           | 1323      | 1.92          | 98        | -40~+80       | 31.56       | 40.1             | 70          |            |
| YDWF102L35P4-□-500 | 1~220         | 50              | 10               | B           | 380           | 1347      | 1.73          | 119       | -40~+85       | 36.23       | 45.2             | 69          |            |
|                    |               |                 |                  | C           | 544           | 1453      | 2.47          | 112       | -40~+80       | 28.59       | 36.5             | 72          |            |
| YDWF102L35P6-□-500 | 1~220         | 50              | 8                | D           | 217           | 849       | 0.99          | 54        | -40~+80       | 23.02       | 33.5             | 66          |            |
|                    |               |                 |                  | E           | 183           | 894       | 0.84          | 58        | -40~+85       | 29.82       | 40.7             | 65          |            |
| YDWF102L35P6-□-500 | 1~220         | 60              | 8                | F           | 258           | 936       | 1.20          | 67        | -40~+85       | 23.48       | 33.4             | 67          |            |
|                    |               |                 |                  | G           | 449           | 1332      | 0.83          | 117       | -40~+80       | 32.47       | 40.9             | 70          |            |
| YSWF102L35P4-□-500 | 3~380         | 50              | —                | H           | 410           | 1353      | 0.87          | 122       | -40~+85       | 32.95       | 41.6             | 70          |            |
|                    |               |                 |                  | J           | 567           | 1516      | 1.01          | 125       | -40~+80       | 31.40       | 39.2             | 73          |            |
| YSWF102L35P6-□-500 | 3~380         | 50              | —                | K           | 218           | 908       | 0.54          | 59        | -40~+80       | 30.45       | 40.8             | 66          |            |
|                    |               |                 |                  | L           | 318           | 1007      | 0.60          | 76        | -40~+85       | 27.80       | 37.2             | 68          |            |

注：性能曲线在安装马尔导风圈时测得。Note: The performance curve is tested with MaEr wall plate.

# MaEr Fan Motor

Professional · Honest · Human Oriented



Ø 500 AC AXIAL FAN 外转子轴流风机

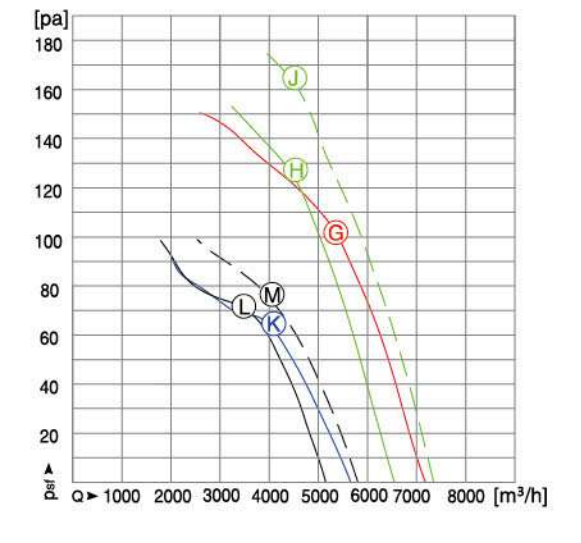
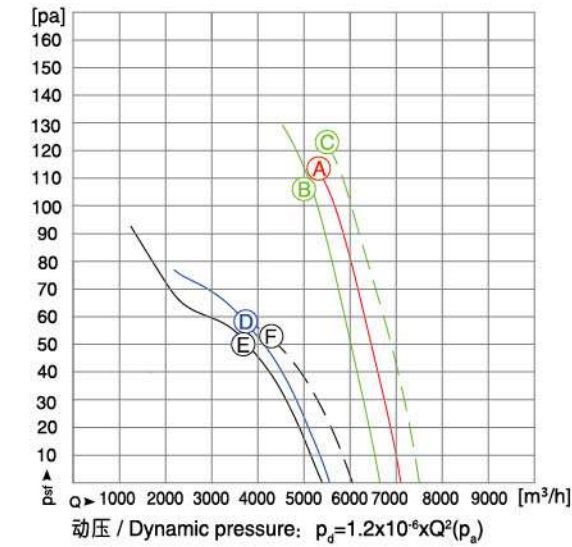

| 型号<br>Model        | 电压<br>Voltage | 频率<br>Frequency | 电容器<br>Capacitor | 曲线<br>Curve | 输入功率<br>Power | 转速<br>RPM | 电流<br>Current | 静压<br>Psf | 环境温度<br>Temp. | 静压效率<br>ηsf | 能效值<br>EFF.Grade | 噪声<br>Noise | 备注<br>Note |
|--------------------|---------------|-----------------|------------------|-------------|---------------|-----------|---------------|-----------|---------------|-------------|------------------|-------------|------------|
|                    | V             | Hz              | μF/450V          | NO.         | W             | r/min     | A             | Pa        | ℃             | %           | N                | dB(A)       |            |
| YDWF102L40P4-□-500 | 1~220         | 50              | 12               | A           | 513           | 1345      | 2.33          | 114       | -40~+65       | 32.6        | 40.7             | 71          |            |
| YDWF102L40P4-□-500 | 1~220         | 50              | 12               | B           | 468           | 1380      | 2.22          | 109       | -40~+85       | 33.08       | 41               | 71          |            |
|                    |               |                 |                  | C           | 731           | 1488      | 3.36          | 122       | -40~+60       | 25.63       | 33               | 73          |            |
| YDWF102L40P6-□-500 | 1~220         | 50              | 10               | D           | 246           | 880       | 1.12          | 57        | -40~+70       | 24.34       | 34.4             | 66          |            |
|                    |               |                 |                  | E           | 240           | 898       | 1.09          | 50        | -40~+70       | 21.67       | 31.8             | 66          |            |
| YDWF102L40P6-□-500 | 1~220         | 60              | 10               | F           | 330           | 958       | 1.51          | 54        | -40~+75       | 18.95       | 28.2             | 68          |            |
|                    |               |                 |                  | G           | 504           | 1329      | 0.90          | 102       | -40~+65       | 29.95       | 38               | 71          |            |
| YSWF102L40P4-□-500 | 3~380         | 50              | —                | H           | 451           | 1347      | 0.83          | 127       | -40~+80       | 34.56       | 43               | 71          |            |
|                    |               |                 |                  | J           | 688           | 1484      | 1.16          | 164       | -40~+60       | 29.51       | 37               | 73          |            |
| YSWF102L40P6-□-500 | 3~380         | 50              | —                | K           | 248           | 918       | 0.60          | 66        | -40~+70       | 28.79       | 38.8             | 66          |            |
|                    |               |                 |                  | L           | 214           | 934       | 0.58          | 71        | -40~+80       | 34.54       | 42               | 66          |            |
| YSWF102L40P6-□-500 | 3~380         | 60              | —                | M           | 288           | 1072      | 0.58          | 76        | -40~+80       | 29.27       | 39               | 68          |            |

注：性能曲线在安装马尔导风圈时测得。Note: The performance curve is tested with MaEr wall plate.

# MaEr Fan Motor

Professional · Honest · Human Oriented



Ø 500 AC AXIAL FAN 外转子轴流风机

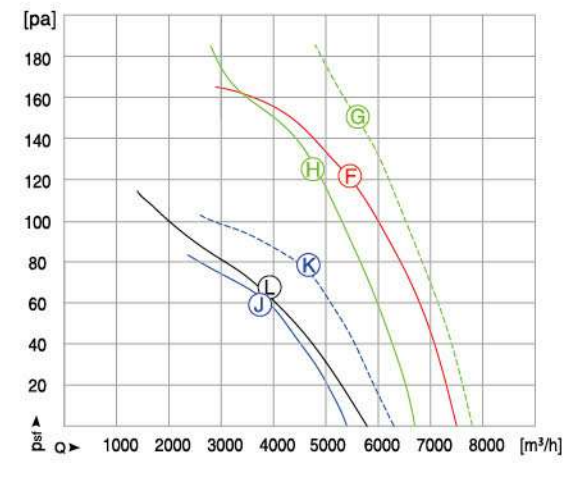
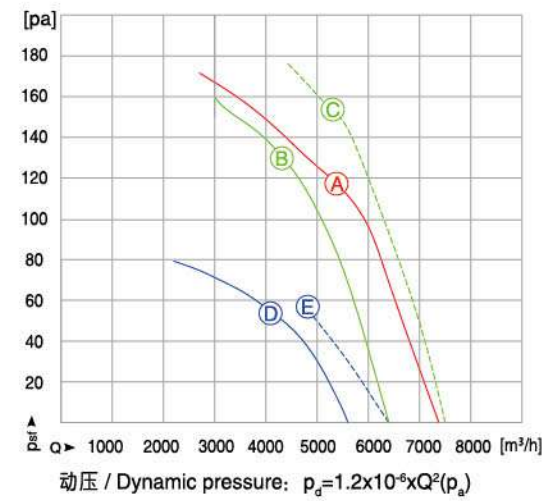

| 型号<br>Model        | 电压<br>Voltage | 频率<br>Frequency | 电容器<br>Capacitor | 曲线<br>Curve | 输入功率<br>Power | 转速<br>RPM | 电流<br>Current | 静压<br>Psf | 环境温度<br>Temp. | 静压效率<br>ηsf | 能效值<br>EFF.Grade | 噪声<br>Noise | 备注<br>Note |
|--------------------|---------------|-----------------|------------------|-------------|---------------|-----------|---------------|-----------|---------------|-------------|------------------|-------------|------------|
|                    | V             | Hz              | μF/450V          | NO.         | W             | r/min     | A             | Pa        | ℃             | %           | N                | dB(A)       |            |
| YDWF102L45P4-□-500 | 1~220         | 50              | 16               | A           | 546           | 1381      | 2.50          | 119       | -40~+70       | 32.74       | 40.6             | 72          |            |
| YDWF102L45P4-□-500 | 1~220         | 50              | 16               | B           | 441           | 1404      | 2.01          | 134       | -40~+75       | 36.55       | 45.0             | 71          |            |
| YDWF102L45P4-□-500 | 1~220         | 60              | 16               | C           | 664           | 1590      | 3.04          | 152       | -40~+65       | 33.49       | 40.8             | 73          |            |
| YDWF102L45P6-□-500 | 1~220         | 50              | 10               | D           | 246           | 911       | 1.11          | 56        | -40~+75       | 25.56       | 35.6             | 66          |            |
| YDWF102L45P6-□-500 | 1~220         | 60              | 10               | E           | 350           | 998       | 1.60          | 58        | -40~+60       | 21.36       | 30.4             | 69          |            |
| YSWF102L45P4-□-500 | 3~380         | 50              | —                | F           | 548           | 1381      | 1.10          | 121       | -40~+75       | 32.58       | 40.4             | 72          |            |
| YSWF102L45P4-□-500 | 3~380         | 50              | —                | H           | 471           | 1404      | 1.02          | 126       | -40~+80       | 35.58       | 43.8             | 71          |            |
| YSWF102L45P4-□-500 | 3~380         | 60              | —                | G           | 705           | 1602      | 1.23          | 152       | -40~+80       | 33.95       | 41.1             | 74          |            |
| YSWF102L45P6-□-500 | 3~380         | 50              | —                | L           | 257           | 929       | 0.69          | 64        | -40~+75       | 27.20       | 37.1             | 68          |            |
| YSWF102L45P6-□-500 | 3~380         | 50              | —                | J           | 224           | 939       | 0.66          | 62        | -40~+80       | 29.83       | 40.1             | 66          |            |
| YSWF102L45P6-□-500 | 3~380         | 60              | —                | K           | 317           | 1078      | 0.67          | 80        | -40~+80       | 31.08       | 40.5             | 69          |            |

注：性能曲线在安装马尔导风圈时测得。Note: The performance curve is tested with MaEr wall plate.

# MaEr Fan Motor

Professional · Honest · Human Oriented



Ø 500 AC AXIAL FAN 外转子轴流风机

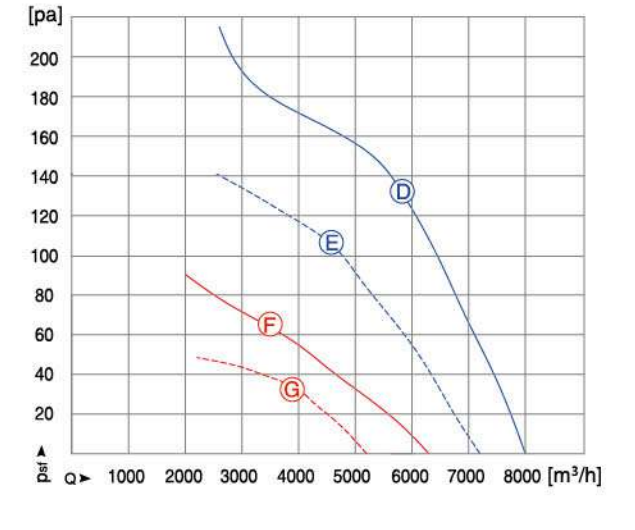
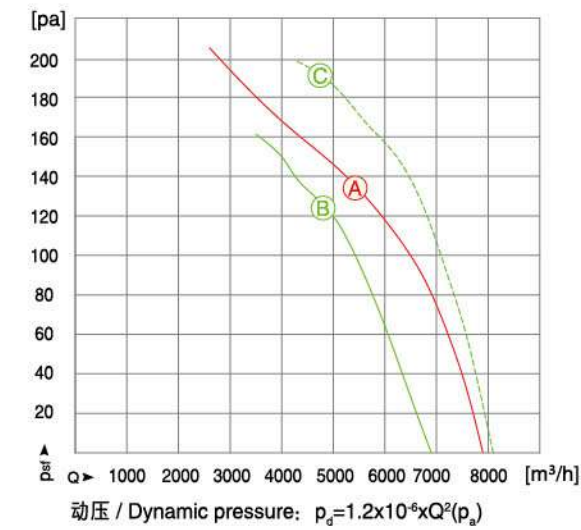

| 型号<br>Model        | 电压<br>Voltage | 频率<br>Frequency | 电容器<br>Capacitor | 曲线<br>Curve | 输入功率<br>Power | 转速<br>RPM | 电流<br>Current | 静压<br>Psf | 环境温度<br>Temp. | 静压效率<br>ηsf | 能效值<br>EFF.Grade | 噪声<br>Noise | 备注<br>Note |
|--------------------|---------------|-----------------|------------------|-------------|---------------|-----------|---------------|-----------|---------------|-------------|------------------|-------------|------------|
|                    | V             | Hz              | μF/450V          | NO.         | W             | r/min     | A             | Pa        | ℃             | %           | N                | dB(A)       |            |
| YDWF102L50P4-□-500 | 1~220         | 50              | 16               | A           | 643           | 1372      | 3.00          | 131       | -40~+70       | 30.78       | 38.2             | 73          |            |
| YDWF102L50P4-□-500 | 1~220         | 50              | 16               | B           | 495           | 1411      | 2.36          | 125       | -40~+85       | 34.10       | 42.2             | 71          |            |
| YDWF102L50P4-□-500 | 1~220         | 60              | 16               | C           | 764           | 1612      | 3.38          | 193       | -40~+75       | 33.95       | 41.0             | 73          |            |
| YSWF102L50P4-□-500 | 3~380△        | 50              | —                | D           | 645           | 1393      | 1.37          | 132       | -40~+70       | 33.16       | 40.6             | 73          |            |
| YSWF102L50P4-□-500 | 3~380Y        | 50              | —                | E           | 511           | 1192      | 0.84          | 107       | -40~+60       | 26.54       | 34.6             | 68          |            |
| YSWF102L50P6-□-500 | 3~380△        | 50              | —                | F           | 313           | 901       | 0.66          | 68        | -40~+90       | 22.34       | 31.7             | 65          |            |
| YSWF102L50P6-□-500 | 3~380Y        | 50              | —                | G           | 217           | 733       | 0.37          | 34        | -40~+80       | 16.72       | 27.1             | 63          |            |

注：性能曲线在安装马尔导风圈时测得。Note: The performance curve is tested with MaEr wall plate.

# MaEr Fan Motor

Professional · Honest · Human Oriented



Ø 500 AC AXIAL FAN 外转子轴流风机

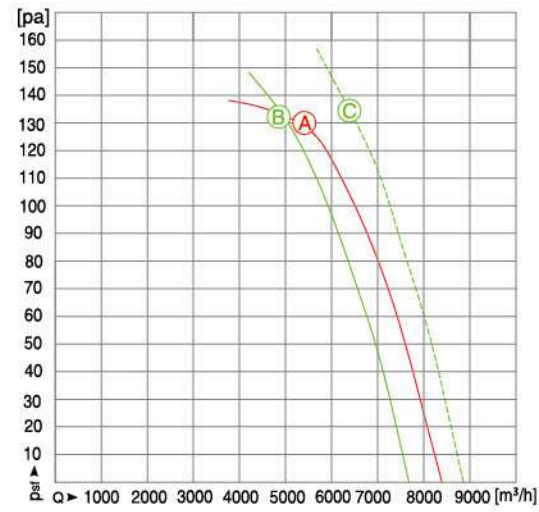

动压 / Dynamic pressure:  $p_d = 1.2 \times 10^{-6} \times Q^2 (p_a)$

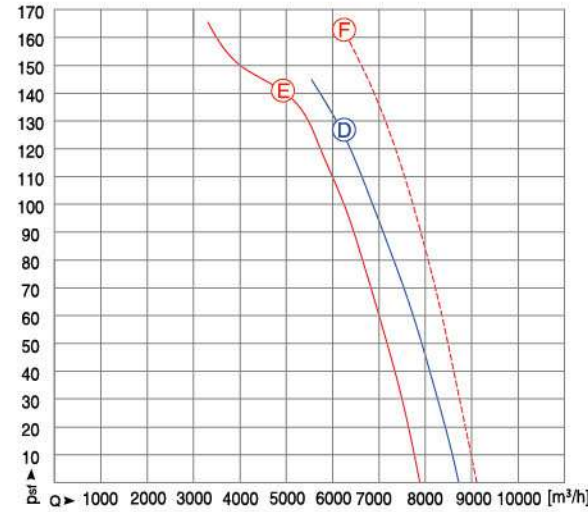

| 型号<br>Model        | 电压<br>Voltage | 频率<br>Frequency | 电容器<br>Capacitor | 曲线<br>Curve | 输入功率<br>Power | 转速<br>RPM | 电流<br>Current | 静压<br>Psf | 环境温度<br>Temp. | 静压效率<br>ηsf | 能效值<br>EFF.Grade | 噪声<br>Noise | 备注<br>Note |
|--------------------|---------------|-----------------|------------------|-------------|---------------|-----------|---------------|-----------|---------------|-------------|------------------|-------------|------------|
|                    | V             | Hz              | μF/450V          | NO.         | W             | r/min     | A             | Pa        | ℃             | %           | N                | dB(A)       |            |
| YDWF102L60P4-□-500 | 1~220         | 50              | 20               | (A)         | 710           | 1364      | 3.23          | 131       | -40~+70       | 27.04       | 34.2             | 73          |            |
| YDWF102L60P4-□-500 | 1~220         | 50              | 20               | (B)         | 591           | 1402      | 2.69          | 133       | -40~+80       | 30.82       | 38.5             | 72          |            |
| YDWF102L60P4-□-500 | 1~220         | 60              | 20               | (C)         | 897           | 1566      | 4.10          | 135       | -40~+65       | 36.64       | 33.2             | 75          |            |
| YSWF102L60P4-□-500 | 3~380         | 50              | —                | (D)         | 733           | 1369      | 1.37          | 127       | -40~+70       | 29.72       | 36.8             | 73          |            |
| YSWF102L60P4-□-500 | 3~380         | 50              | —                | (E)         | 616           | 1401      | 1.26          | 141       | -40~+80       | 31.11       | 38.7             | 72          |            |
| YSWF102L60P4-□-500 | 3~380         | 60              | —                | (F)         | 948           | 1594      | 1.62          | 165       | -40~+65       | 29.82       | 36.2             | 75          |            |

注：性能曲线在安装马尔导风圈时测得。Note: The performance curve is tested with MaEr wall plate.

# MaEr Fan Motor

Professional · Honest · Human Oriented



Ø 500 AC AXIAL FAN 外转子轴流风机

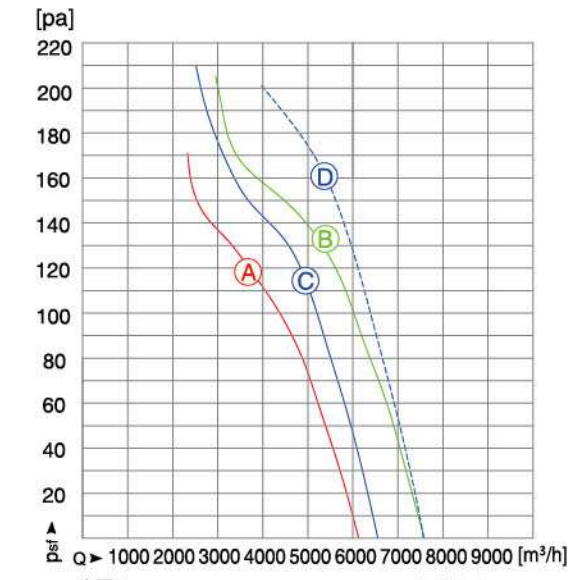

动压 / Dynamic pressure:  $p_d = 1.2 \times 10^{-6} \times Q^2 (p_a)$

| 型号<br>Model           | 电压<br>Voltage | 频率<br>Frequency | 电容器<br>Capacitor | 曲线<br>Curve | 输入功率<br>Power | 转速<br>RPM | 电流<br>Current | 静压<br>Psf | 环境温度<br>Temp. | 静压效率<br>ηsf | 能效值<br>EFF.Grade | 噪声<br>Noise | 备注<br>Note |
|-----------------------|---------------|-----------------|------------------|-------------|---------------|-----------|---------------|-----------|---------------|-------------|------------------|-------------|------------|
|                       | V             | Hz              | μF/450V          | NO.         | W             | r/min     | A             | Pa        | ℃             | %           | N                | dB(A)       |            |
| YSWF102L35P4-□-500-4F | 3~380         | 50              | —                | (A)         | 419           | 1353      | 0.80          | 117       | -40~+65       | 30.24       | 38.8             | 74          |            |
| YSWF102L45P4-□-500-4F | 3~380         | 50              | —                | (B)         | 610           | 1408      | 1.43          | 133       | -40~+80       | 31.22       | 39               | 76          |            |
| YSWF102L45P4-□-500-4F | 3~380         | 50              | —                | (C)         | 468           | 1407      | 1.05          | 116       | -40~+85       | 33.93       | 42.3             | 75          |            |
| YSWF102L45P4-□-500-4F | 3~380         | 60              | —                | (D)         | 725           | 1601      | 1.27          | 162       | -40~+70       | 33.29       | 40.4             | 78          |            |

注：性能曲线在安装马尔导风圈时测得。Note: The performance curve is tested with MaEr wall plate.

# MaEr Fan Motor

Professional · Honest · Human Oriented



Ø 500 AC AXIAL FAN 外转子轴流风机

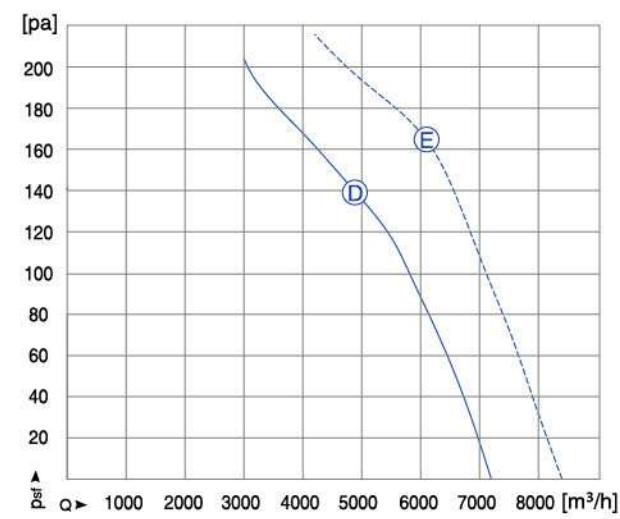
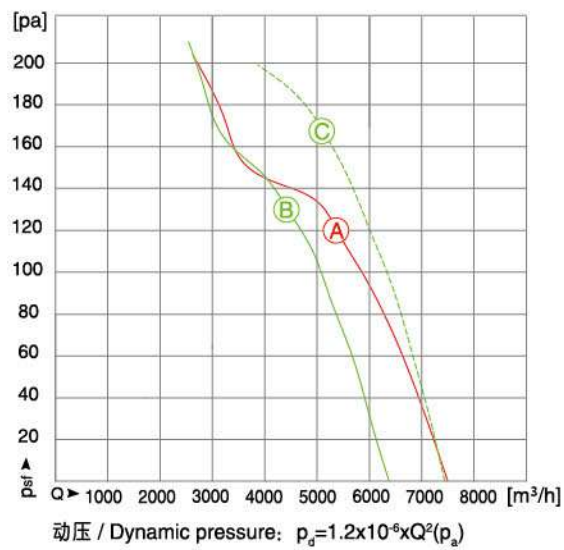

| 型号<br>Model           | 电压<br>Voltage | 频率<br>Frequency | 电容器<br>Capacitor | 曲线<br>Curve | 输入功率<br>Power | 转速<br>RPM | 电流<br>Current | 静压<br>Psf | 环境温度<br>Temp. | 静压效率<br>$\eta_{sf}$ | 能效值<br>EFF.Grade | 噪声<br>Noise | 备注<br>Note |
|-----------------------|---------------|-----------------|------------------|-------------|---------------|-----------|---------------|-----------|---------------|---------------------|------------------|-------------|------------|
|                       | V             | Hz              | $\mu$ F/450V     | NO.         | W             | r/min     | A             | Pa        | $^{\circ}$ C  | %                   | N                | dB(A)       |            |
| YDWF102L50P4-□-500-4F | 1~220         | 50              | 16               | A           | 603           | 1379      | 2.74          | 121       | -40~+70       | 29.73               | 37.4             | 73          |            |
| YDWF102L50P4-□-500-4F | 1~220         | 50              | 16               | B           | 482           | 1414      | 2.20          | 130       | -40~+85       | 33.21               | 41.5             | 73          |            |
|                       |               | 60              |                  | C           | 745           | 1615      | 3.40          | 168       | -40~+75       | 31.94               | 39               | 76          |            |
| YSWF102L50P4-□-500-4F | 3~380         | 50              | —                | D           | 541           | 1408      | 1.14          | 139       | -40~+85       | 34.84               | 42.7             | 74          |            |
|                       |               | 60              |                  | E           | 820           | 1614      | 1.40          | 164       | -40~+75       | 34.10               | 40.9             | 77          |            |

注：性能曲线在安装马尔导风圈时测得。Note: The performance curve is tested with MaEr wall plate.

# MaEr Fan Motor

Professional · Honest · Human Oriented



Ø 500 AC AXIAL FAN 外转子轴流风机

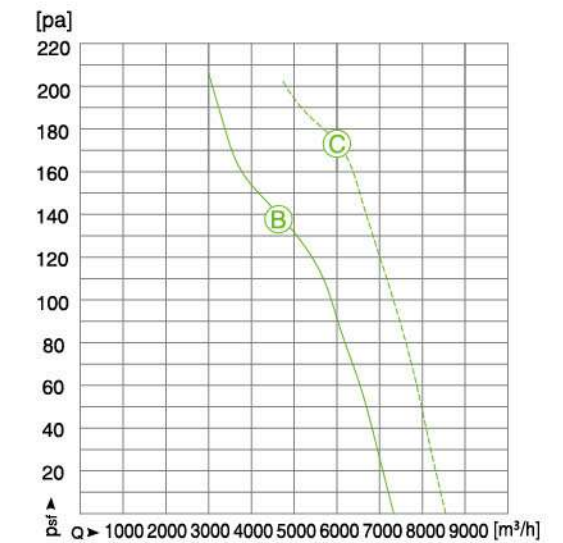
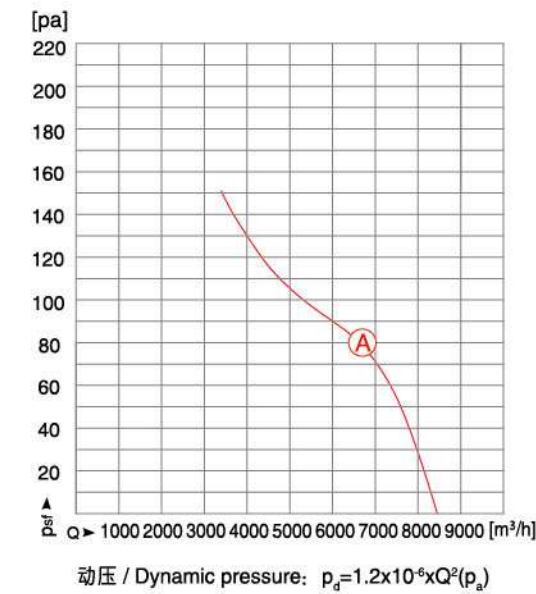

| 型号<br>Model           | 电压<br>Voltage | 频率<br>Frequency | 电容器<br>Capacitor | 曲线<br>Curve | 输入功率<br>Power | 转速<br>RPM | 电流<br>Current | 静压<br>Psf | 环境温度<br>Temp. | 静压效率<br>$\eta_{sf}$ | 能效值<br>EFF.Grade | 噪声<br>Noise | 备注<br>Note |
|-----------------------|---------------|-----------------|------------------|-------------|---------------|-----------|---------------|-----------|---------------|---------------------|------------------|-------------|------------|
|                       | V             | Hz              | $\mu$ F/450V     | NO.         | W             | r/min     | A             | Pa        | $^{\circ}$ C  | %                   | N                | dB(A)       |            |
| YSWF102L60P4-□-500-4F | 3~380         | 50              | —                | A           | 751           | 1400      | 1.60          | 84        | -40~+70       | 20.02               | 27               | 75          |            |
| YSWF102L60P4-□-500-4F | 3~380         | 50              | —                | B           | 591           | 1422      | 1.38          | 132       | -40~+80       | 32.18               | 39.9             | 74          |            |
|                       |               | 60              |                  | C           | 891           | 1642      | 1.60          | 175       | -40~+70       | 32.41               | 39               | 79          |            |

注：性能曲线在安装马尔导风圈时测得。Note: The performance curve is tested with MaEr wall plate.

# MaEr Fan Motor

Professional · Honest · Human Oriented



Ø 500 AC AXIAL FAN 外转子轴流风机

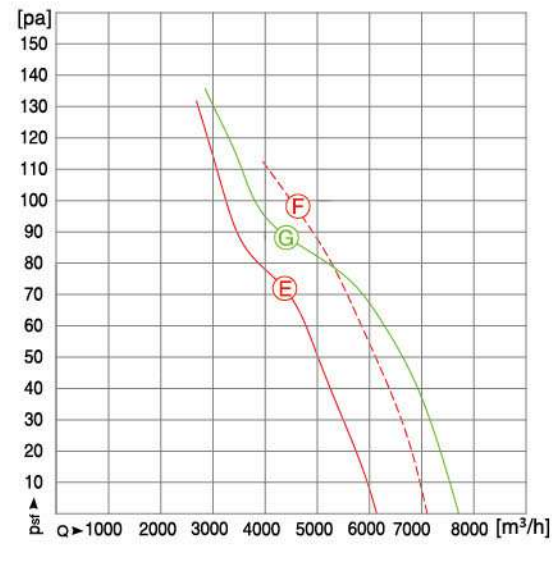
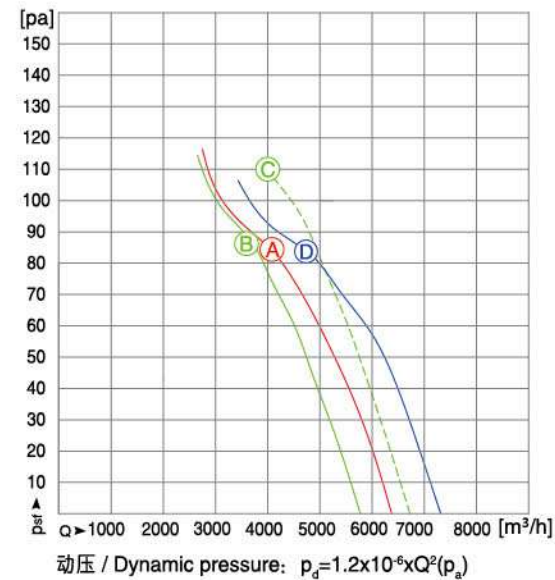

| 型号<br>Model           | 电压<br>Voltage | 频率<br>Frequency | 电容器<br>Capacitor | 曲线<br>Curve | 输入功率<br>Power | 转速<br>RPM | 电流<br>Current | 静压<br>Psf | 环境温度<br>Temp. | 静压效率<br>ηsf | 能效值<br>EFF.Grade | 噪声<br>Noise | 备注<br>Note |
|-----------------------|---------------|-----------------|------------------|-------------|---------------|-----------|---------------|-----------|---------------|-------------|------------------|-------------|------------|
|                       | V             | Hz              | μF/450V          | NO.         | W             | r/min     | A             | Pa        | ℃             | %           | N                | dB(A)       |            |
| YDWF102L35P4-□-500-7F | 1~220         | 50              | 10               | A           | 366           | 1366      | 1.66          | 85        | -40~+70       | 25.96       | 34.9             | 73          |            |
| YDWF102L35P4-□-500-7F | 1~220         | 50              | 10               | B           | 312           | 1393      | 1.43          | 87        | -40~+85       | 28.52       | 37.9             | 72          |            |
| YDWF102L35P4-□-500-7F | 1~220         | 60              | 10               | C           | 490           | 1540      | 2.22          | 110       | -40~+65       | 24.76       | 32.9             | 74          |            |
| YDWF102L40P4-□-500-7F | 1~220         | 50              | 12               | D           | 466           | 1368      | 2.11          | 83        | -40~+70       | 23.73       | 32.1             | 74          |            |
| YDWF102L40P4-□-500-7F | 1~220         | 50              | 12               | E           | 344           | 1405      | 1.57          | 73        | -40~+85       | 25.37       | 34.6             | 72          |            |
| YDWF102L40P4-□-500-7F | 1~220         | 60              | 12               | F           | 530           | 1580      | 2.43          | 98        | -40~+65       | 23.58       | 31.6             | 75          |            |
| YDWF102L45P4-□-500-7F | 1~220         | 50              | 16               | G           | 515           | 1386      | 2.34          | 87        | -40~+75       | 22.60       | 30.7             | 75          |            |

注：性能曲线在安装马尔导风圈时测得。Note: The performance curve is tested with MaEr wall plate.

# MaEr Fan Motor

Professional · Honest · Human Oriented



Ø 500 AC AXIAL FAN 外转子轴流风机

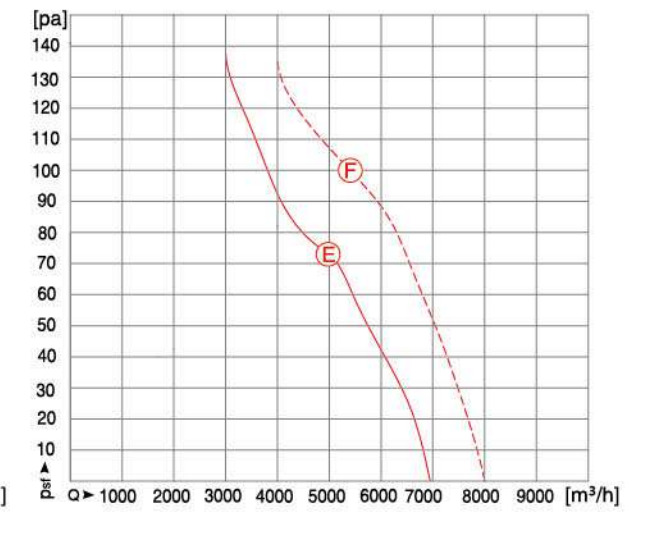
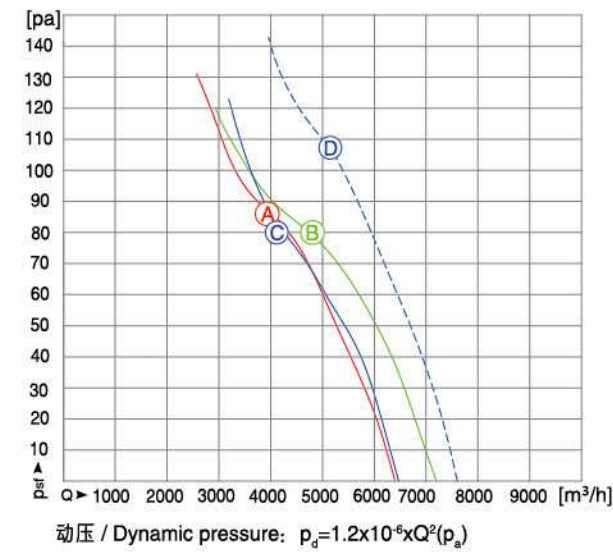

| 型号<br>Model           | 电压<br>Voltage | 频率<br>Frequency | 电容器<br>Capacitor | 曲线<br>Curve | 输入功率<br>Power | 转速<br>RPM | 电流<br>Current | 静压<br>Psf | 环境温度<br>Temp. | 静压效率<br>ηsf | 能效值<br>EFF.Grade | 噪声<br>Noise | 备注<br>Note |
|-----------------------|---------------|-----------------|------------------|-------------|---------------|-----------|---------------|-----------|---------------|-------------|------------------|-------------|------------|
|                       | V             | Hz              | μF/450V          | NO.         | W             | r/min     | A             | Pa        | ℃             | %           | N                | dB(A)       |            |
| YSWF102L35P4-□-500-7F | 3~380         | 50              | —                | A           | 380           | 1374      | 0.75          | 86        | -40~+75       | 25.30       | 34.2             | 73          |            |
| YSWF102L40P4-□-500-7F | 3~380         | 50              | —                | B           | 445           | 1354      | 0.83          | 80        | -40~+75       | 23.68       | 32.1             | 74          |            |
| YSWF102L45P4-□-500-7F | 3~380         | 50              | —                | C           | 386           | 1429      | 0.96          | 83        | -40~+80       | 24.55       | 33.4             | 73          |            |
| YSWF102L45P4-□-500-7F | 3~380         | 60              | —                | D           | 582           | 1659      | 1.07          | 107       | -40~+75       | 26.29       | 34.0             | 76          |            |
| YSWF102L50P4-□-500-7F | 3~380         | 50              | —                | E           | 419           | 1410      | 0.91          | 73        | -40~+80       | 24.11       | 32.8             | 73          |            |
| YSWF102L50P4-□-500-7F | 3~380         | 60              | —                | F           | 641           | 1609      | 1.12          | 100       | -40~+75       | 23.33       | 30.8             | 76          |            |

注：性能曲线在安装马尔导风圈时测得。Note: The performance curve is tested with MaEr wall plate.

# MaEr Fan Motor

Professional · Honest · Human Oriented



Ø 500 AC AXIAL FAN 外转子轴流风机

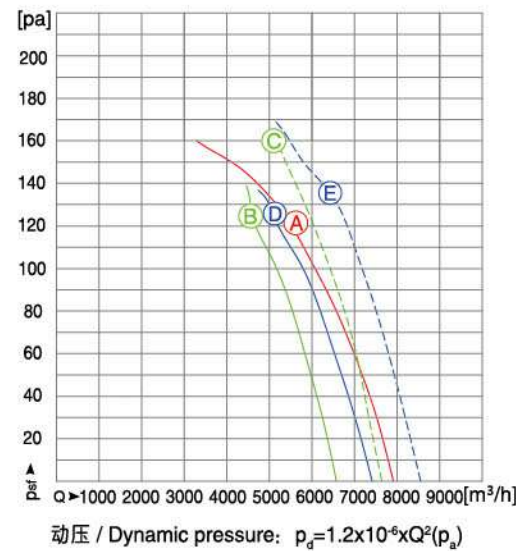

| 型号<br>Model          | 电压<br>Voltage | 频率<br>Frequency | 电容器<br>Capacitor | 曲线<br>Curve | 输入功率<br>Power | 转速<br>RPM | 电流<br>Current | 静压<br>Psf | 环境温度<br>Temp. | 静压效率<br>ηsf | 能效值<br>EFF.Grade | 噪声<br>Noise | 备注<br>Note |
|----------------------|---------------|-----------------|------------------|-------------|---------------|-----------|---------------|-----------|---------------|-------------|------------------|-------------|------------|
|                      | V             | Hz              | μF/450V          | NO.         | W             | r/min     | A             | Pa        | ℃             | %           | N                | dB(A)       |            |
| YDWF102L50P4-□-500-7 | 1~220         | 50              | 16               | A           | 661           | 1356      | 3.00          | 124       | -40~+70       | 28.08       | 35.5             | 73          |            |
| YDWF102L50P4-□-500-7 | 1~220         | 50              | 16               | B           | 508           | 1407      | 2.31          | 126       | -40~+75       | 31.70       | 39.8             | 71          |            |
|                      |               |                 |                  | C           | 793           | 1584      | 3.61          | 159       | -40~+75       | 29.12       | 36               | 74          |            |
| YDWF102L60P4-□-500-7 | 1~220         | 50              | 20               | D           | 583           | 1399      | 2.65          | 123       | -40~+75       | 30.08       | 37.8             | 72          |            |
|                      |               |                 |                  | E           | 883           | 1578      | 4.05          | 136       | -40~+75       | 27.39       | 34               | 75          |            |

注：性能曲线在安装马尔导风圈时测得。Note: The performance curve is tested with MaEr wall plate.

# MaEr Fan Motor

Professional · Honest · Human Oriented



Ø 500 AC AXIAL FAN 外转子轴流风机

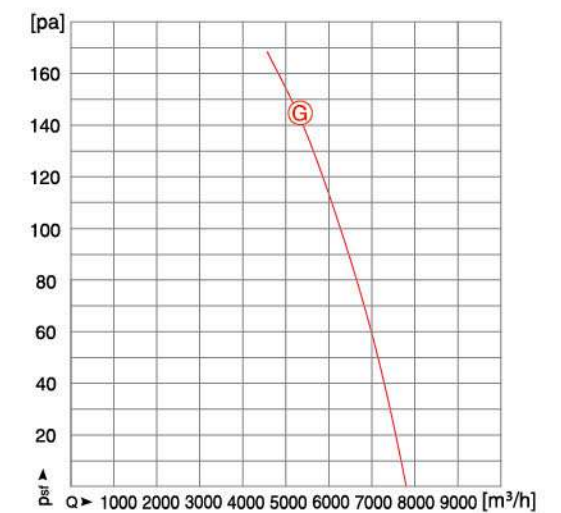
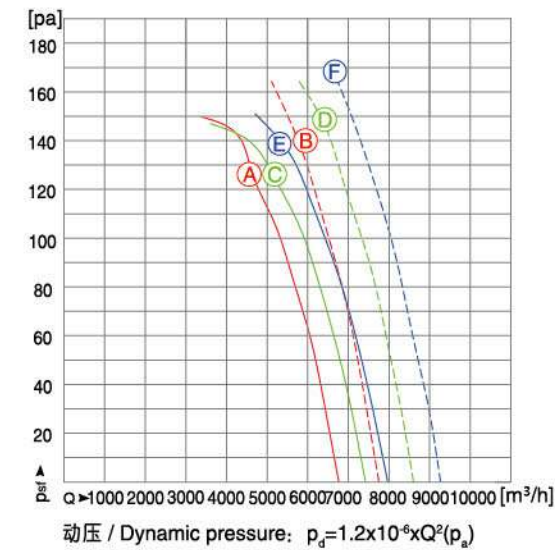

| 型号<br>Model          | 电压<br>Voltage | 频率<br>Frequency | 电容器<br>Capacitor | 曲线<br>Curve | 输入功率<br>Power | 转速<br>RPM | 电流<br>Current | 静压<br>Psf | 环境温度<br>Temp. | 静压效率<br>ηsf | 能效值<br>EFF.Grade | 噪声<br>Noise | 备注<br>Note |
|----------------------|---------------|-----------------|------------------|-------------|---------------|-----------|---------------|-----------|---------------|-------------|------------------|-------------|------------|
|                      | V             | Hz              | μF/450V          | NO.         | W             | r/min     | A             | Pa        | ℃             | %           | N                | dB(A)       |            |
| YSWF102L50P4-□-500-7 | 3~380         | 50              | —                | A           | 507           | 1407      | 1.00          | 128       | -40~+80       | 32.31       | 40.4             | 71          |            |
|                      |               |                 |                  | B           | 741           | 1604      | 1.26          | 141       | -40~+75       | 30.31       | 37.4             | 74          |            |
| YSWF102L60P4-□-500-7 | 3~380         | 50              | —                | C           | 582           | 1407      | 1.23          | 127       | -40~+80       | 31.02       | 38.8             | 72          |            |
|                      |               |                 |                  | D           | 883           | 1608      | 1.52          | 149       | -40~+75       | 29.70       | 36.3             | 75          |            |
| YSWF102L70P4-□-500-7 | 3~380         | 50              | —                | E           | 664           | 1418      | 1.50          | 137       | -40~+80       | 31.33       | 38.7             | 74          |            |
|                      |               |                 |                  | F           | 1027          | 1627      | 1.82          | 171       | -40~+75       | 30.31       | 36.6             | 77          |            |
| YSWF102L50P4-□-500-7 | 3~380         | 50              | —                | G           | 661           | 1401      | 1.44          | 145       | -40~+70       | 32.71       | 40.1             | 72          |            |

注：性能曲线在安装马尔导风圈时测得。Note: The performance curve is tested with MaEr wall plate.

## Ø 500 AC AXIAL FAN 外转子轴流风机

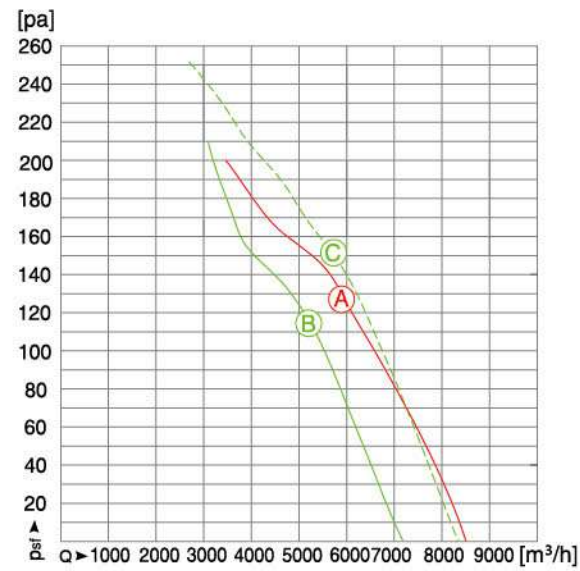

动压 / Dynamic pressure:  $p_d = 0.82 \times 10^{-6} \times Q^2 (p_a)$

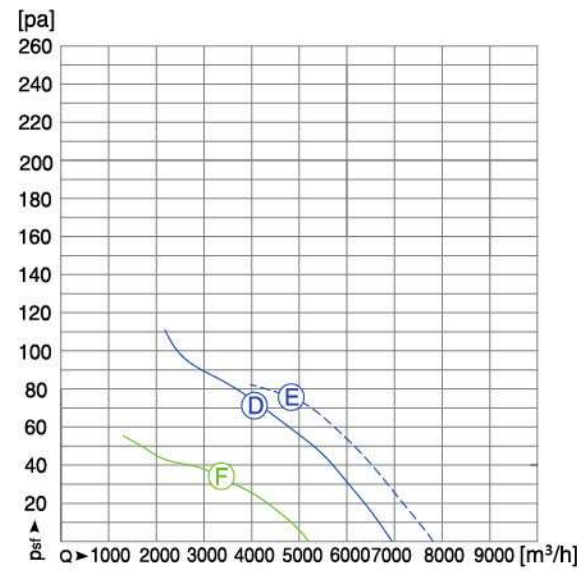

| 型号<br>Model        | 电压<br>Voltage | 频率<br>Frequency | 电容器<br>Capacitor | 曲线<br>Curve | 输入功率<br>Power | 转速<br>RPM | 电流<br>Current | 静压<br>Psf | 环境温度<br>Temp. | 静压效率<br>ηsf | 能效值<br>EFF.Grade | 噪声<br>Noise | 备注<br>Note |
|--------------------|---------------|-----------------|------------------|-------------|---------------|-----------|---------------|-----------|---------------|-------------|------------------|-------------|------------|
|                    | V             | Hz              | μF/450V          | NO.         | W             | r/min     | A             | Pa        | ℃             | %           | N                | dB(A)       |            |
| YDWF102L50P4-□-550 | 1~220         | 50              | 16               | A           | 639           | 1361      | 2.90          | 126       | -40~+70       | 32.8        | 40.2             | 74          |            |
| YDWF102L50P4-□-550 | 1~220         | 50              | 16               | B           | 516           | 1408      | 2.44          | 116       | -40~+85       | 32.5        | 40.6             | 73          |            |
|                    |               |                 |                  | C           | 808           | 1587      | 3.68          | 150       | -40~+70       | 29.5        | 36.3             | 76          |            |
| YDWF102L50P6-□-550 | 1~220         | 50              | 12               | D           | 348           | 897       | 1.59          | 72        | -40~+70       | 23.85       | 33               | 69          |            |
|                    |               |                 |                  | E           | 460           | 985       | 2.24          | 75        | -40~+60       | 20.31       | 28.5             | 70          |            |
| YDWF102L50P8-□-550 | 1~220         | 50              | 8                | F           | 183           | 656       | 0.83          | 33        | -40~+80       | 16.99       | 28               | 60          |            |

注：性能曲线在安装马尔导风圈时测得。Note: The performance curve is tested with MaEr wall plate.

## Ø 500 INSTALLATION ACCESSORIES 安装附件

### □-570N

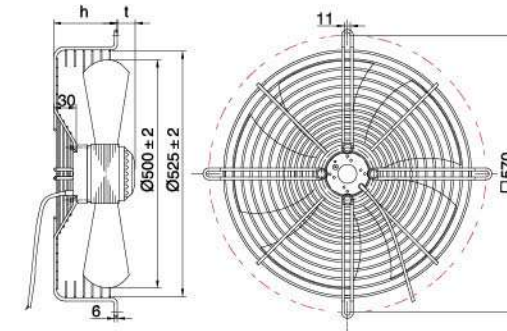

| 常规凹网罩 Concave grid 570N  |    |    | 低凹网罩 Low concave grid 570N40 |    |     |
|--------------------------|----|----|------------------------------|----|-----|
| 型号 MODEL                 | h  | t  | 型号 MODEL                     | h  | t   |
| YD(S)WF102L35P4-570N-500 | 90 | 47 | YD(S)WF102L35P4-570N40-500   | 40 | 97  |
| YD(S)WF102L35P6-570N-500 | 90 | 47 | YD(S)WF102L35P6-570N40-500   | 40 | 97  |
| YD(S)WF102L40P4-570N-500 | 90 | 52 | YD(S)WF102L40P4-570N40-500   | 40 | 102 |
| YD(S)WF102L40P6-570N-500 | 90 | 52 | YD(S)WF102L40P6-570N40-500   | 40 | 102 |
| YD(S)WF102L45P4-570N-500 | 90 | 57 | YD(S)WF102L45P4-570N40-500   | 40 | 107 |
| YD(S)WF102L45P6-570N-500 | 90 | 57 | YD(S)WF102L45P6-570N40-500   | 40 | 107 |
| YSWF102L45P8-570N-500    | 90 | 57 | YSWF102L45P8-570N40-500      | 40 | 107 |
| YD(S)WF102L50P4-570N-500 | 90 | 62 | YD(S)WF102L50P4-570N40-500   | 40 | 112 |
| YSWF102L50P6-570N-500    | 90 | 62 | YSWF102L50P6-570N40-500      | 40 | 112 |
| YD(S)WF102L60P4-570N-500 | 90 | 72 | YD(S)WF102L60P4-570N40-500   | 40 | 122 |

### □-615H

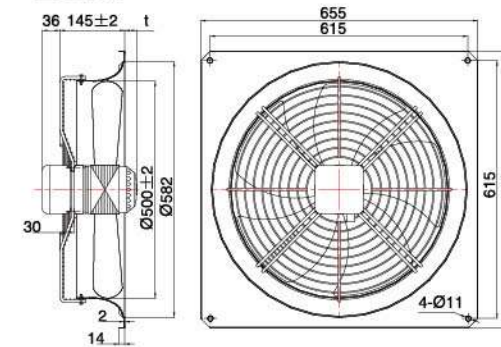

| 带导风圈 Wall plate 615H     |    | t |
|--------------------------|----|---|
| 型号 MODEL                 |    |   |
| YD(S)WF102L35P4-615H-500 | —  | — |
| YD(S)WF102L35P6-615H-500 | —  | — |
| YD(S)WF102L40P4-615H-500 | —  | — |
| YD(S)WF102L40P6-615H-500 | 3  | — |
| YD(S)WF102L45P4-615H-500 | 3  | — |
| YD(S)WF102L45P6-615H-500 | 3  | — |
| YSWF102L45P8-615H-500    | 8  | — |
| YD(S)WF102L50P4-615H-500 | 8  | — |
| YSWF102L50P6-615H-500    | 18 | — |
| YD(S)WF102L60P4-615H-500 | 28 | — |

### □-545G

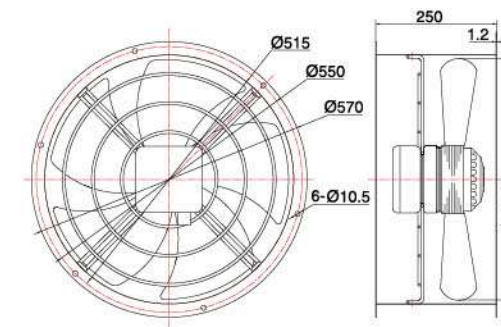

| 带风筒 Air duct 545G        |   |
|--------------------------|---|
| 型号 MODEL                 |   |
| YD(S)WF102L35P4-545G-500 | — |
| YD(S)WF102L35P6-545G-500 | — |
| YD(S)WF102L40P4-545G-500 | — |
| YD(S)WF102L40P6-545G-500 | — |
| YD(S)WF102L45P4-545G-500 | — |
| YD(S)WF102L45P6-545G-500 | — |
| YSWF102L45P8-545G-500    | — |
| YD(S)WF102L50P4-545G-500 | — |
| YSWF102L50P6-545G-500    | — |
| YD(S)WF102L60P4-545G-500 | — |

### □-其他安装附件 Others

| 平板网罩 Flat screen grid 570P |    |    | 平板网罩 Flat net grid 570B  |   |     | 凹板网罩 Concave flat grid 570NB |   |     |
|----------------------------|----|----|--------------------------|---|-----|------------------------------|---|-----|
| 型号 MODEL                   | h  | t  | 型号 MODEL                 | h | t   | 型号 MODEL                     | h | t   |
| YD(S)WF102L35P4-570P-500   | 90 | 17 | YD(S)WF102L35P4-570B-500 | — | 107 | YD(S)WF102L35P4-570NB-500    | — | 137 |
| YD(S)WF102L35P6-570P-500   | 90 | 17 | YD(S)WF102L35P6-570B-500 | — | 107 | YD(S)WF102L35P6-570NB-500    | — | 137 |
| YD(S)WF102L40P4-570P-500   | 90 | 22 | YD(S)WF102L40P4-570B-500 | — | 112 | YD(S)WF102L40P4-570NB-500    | — | 142 |
| YD(S)WF102L40P6-570P-500   | 90 | 22 | YD(S)WF102L40P6-570B-500 | — | 112 | YD(S)WF102L40P6-570NB-500    | — | 142 |
| YD(S)WF102L45P4-570P-500   | 90 | 27 | YD(S)WF102L45P4-570B-500 | — | 117 | YD(S)WF102L45P4-570NB-500    | — | 147 |
| YD(S)WF102L45P6-570P-500   | 90 | 27 | YD(S)WF102L45P6-570B-500 | — | 117 | YD(S)WF102L45P6-570NB-500    | — | 147 |
| YSWF102L45P8-570P-500      | 90 | 27 | YSWF102L45P8-570B-500    | — | 117 | YSWF102L45P8-570NB-500       | — | 147 |
| YD(S)WF102L50P4-570P-500   | 90 | 32 | YD(S)WF102L50P4-570B-500 | — | 122 | YD(S)WF102L50P4-570NB-500    | — | 152 |
| YSWF102L50P6-570P-500      | 90 | 32 | YSWF102L50P6-570B-500    | — | 122 | YSWF102L50P6-570NB-500       | — | 152 |
| YD(S)WF102L60P4-570P-500   | 90 | 42 | YD(S)WF102L60P4-570B-500 | — | 132 | YD(S)WF102L60P4-570NB-500    | — | 162 |